

WICHTIG: Bevor Sie mit der Installation des Produkts beginnen, lesen Sie die beigefügten **WICHTIGEN SICHERHEITSHINWEISE** aufmerksam durch und befolgen Sie diese Informationen sorgfältig!

Beschreibung:
IO-Modul mit Ethernet und MODBUS/TCP-Server und ASCII-Textprotokoll, 16 Universelle Analoge Ein- oder Ausgänge, 0-10V, 0/4-20mA, RTD Sensoren 0-1MQ, PT100, PT1000, NI1000, Logik Eingang: $\leq 40V$, $\leq 1.8mA$, pro Kanal individuell konfigurierbar, Größe (LxBxH): 72x110x62mm, Gewicht: 210g, Spannungsversorgung: 12-48V=, Leistungsaufnahme: 7.3W, Gehäuse: 4TE, Montage: Schnappbar auf EN50022 DIN Schiene oder Wandmontage, Klemmen: Klemmentyp RM5, Kabelquerschnitt: max. 2.5 mm², max. 14AWG, Schraube: M3, Anzugsmoment: max. 0.5Nm, max. 4.43 Lb-in, Klemmentyp RM3.5, Kabelquerschnitt: max. 1.5 mm², max. 16AWG, Schraube: M2, Anzugsmoment: max. 0.2Nm, max. 1.77 Lb-in, Zertifizierung: CE, Schutzklasse: IP20, TARIC Nummer: 8538 90 91

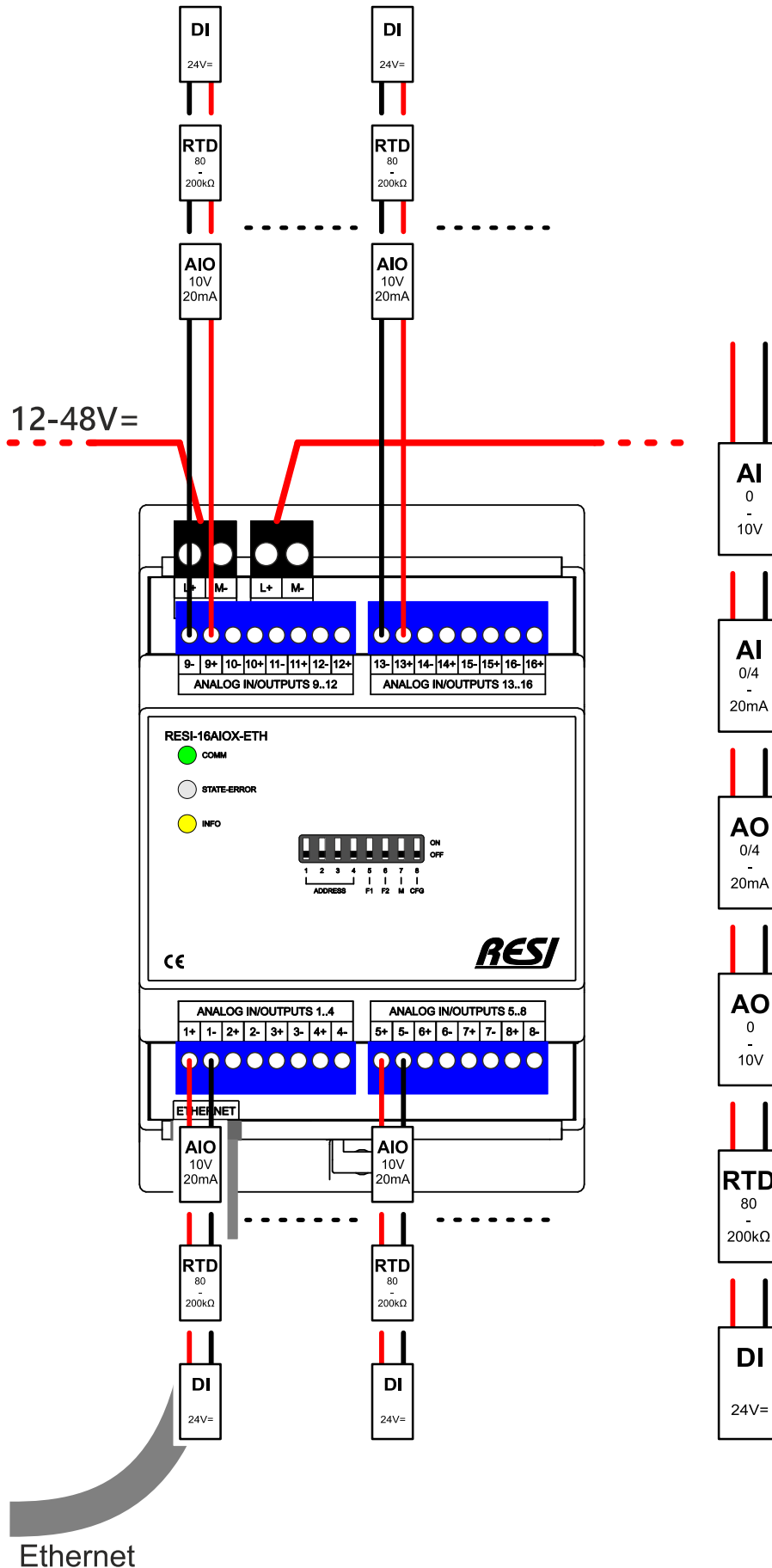

WICHTIG: Bevor Sie mit der Installation des Produkts beginnen, lesen Sie die beigefügten **WICHTIGEN SICHERHEITSHINWEISE** aufmerksam durch und befolgen Sie diese Informationen sorgfältig!

<p>KLEMMEN: L+, M- Zwei 2-polige Steckklemmen RM5 Spannungsversorgung für Daisy-chain IN und OUT von vielen IO Modulen 1 L+ 12-48 V= 2 M- Masse</p> <p>ETH Ethernet Schnittstelle, RJ45</p> <p>UNIVERSELLE ANALOGE EIN/AUSGÄNGE Sechzehn 2-polige Steckklemmen RM3.5 Jeder EA individuell konfigurierbar: Analogeingang 0-10V Analogausgang 0-10V Analogeingang 0/4-20mA Analogausgang 0/4-20mA RTD Sensoreingang 0-200kOhm Digitaleingang 24V</p> <p>KLEMMEN 1..16 2-polige Steckklemme 1 AIOX+ Positives Signal für AE/AA/RTDE/DE 2 AIOX- Negatives Signal für AE/AA/RTDE/DE</p> <p>LEDs: COMM Zeigt an, ob derzeit Daten über die Ethernet-Schnittstelle gesendet oder empfangen werden</p> <p>STATE-ERROR Die Status-LED blinkt langsam (ca. 1 s) in WEISS, wenn das Modul in Ordnung ist. Blinkt schnell in ROT, wenn das Modul einen internen Fehler aufweist</p> <p>INFO Blinkt zyklisch als Zeichen, dass der Analogteil korrekt arbeitet</p>	<p>DIP SCHALTER: ADDRESS Diese vier DIP-Schalter ID3-ID0 bilden die MODBUS Unit ID oder ASCII-Busadresse. Sie können die folgenden Einstellungen verwenden:</p> <table border="1"> <thead> <tr> <th>ID3</th> <th>ID2</th> <th>ID1</th> <th>ID0</th> <th>MODBUS Unit ID oder ASCII-Busnummer</th> </tr> </thead> <tbody> <tr><td>1=ID0</td><td></td><td></td><td></td><td>255</td></tr> <tr><td>2=ID1</td><td></td><td></td><td></td><td>1</td></tr> <tr><td>3=ID2</td><td>AUS</td><td>AUS</td><td>AUS</td><td>2</td></tr> <tr><td>4=ID3</td><td>AUS</td><td>AUS</td><td>EIN</td><td>3</td></tr> <tr><td></td><td>AUS</td><td>AUS</td><td>EIN</td><td>4</td></tr> <tr><td></td><td>AUS</td><td>EIN</td><td>AUS</td><td>5</td></tr> <tr><td></td><td>AUS</td><td>EIN</td><td>EIN</td><td>6</td></tr> <tr><td></td><td>AUS</td><td>EIN</td><td>EIN</td><td>7</td></tr> <tr><td></td><td>EIN</td><td>AUS</td><td>AUS</td><td>8</td></tr> <tr><td></td><td>EIN</td><td>AUS</td><td>AUS</td><td>9</td></tr> <tr><td></td><td>EIN</td><td>AUS</td><td>EIN</td><td>10</td></tr> <tr><td></td><td>EIN</td><td>AUS</td><td>EIN</td><td>11</td></tr> <tr><td></td><td>EIN</td><td>EIN</td><td>AUS</td><td>12</td></tr> <tr><td></td><td>EIN</td><td>EIN</td><td>AUS</td><td>13</td></tr> <tr><td></td><td>EIN</td><td>EIN</td><td>EIN</td><td>14</td></tr> </tbody> </table> <p>Interne MODBUS Unit ID von 0 bis 255 aus den FLASH Speicher wird verwendet</p> <p>5=F1 DHCP Wenn dieser DIP-Schalter beim Hochfahren aktiviert wird, wird die interne IP-Konfiguration auf DHCP-Einstellungen für das Ethernet geändert. Warten Sie, bis die STATE-LED sehr schnell weiß blinkt. Anschließend alle DIP-Schalter auf AUS stellen und das Modul neu starten (Aus- und wieder einschalten)!</p> <p>6=F2 STATIC Wenn dieser DIP-Schalter beim Hochfahren aktiviert wird, wird die interne IP-Konfiguration auf STATIC Einstellungen für das Ethernet mit der Standard-IP-Adresse des Moduls geändert. Warten Sie, bis die STATE-LED sehr schnell weiß blinkt. Anschließend alle DIP-Schalter auf AUS stellen und das Modul neu starten (Aus- und wieder einschalten)!</p> <p>7=M MODE Dieser DIP-Schalter wird zusammen mit dem DIP-Schalter 8=CFG verwendet. Wenn dieser DIP-Schalter beim Hochfahren auf 0 (AUS) oder 1 (EIN) gestellt ist und der DIP-Schalter 8=CFG auf 1 (EIN) gesetzt wird, erfolgt eine vollständige Konfiguration und ein Werksreset des Moduls: Die IP-Schnittstelle wird auf STATISCHE IP-Adresse mit der Standard-IP-Adresse des Moduls eingestellt, der Benutzername und das Passwort werden auf die Standardwerte geändert und alle modulspezifischen Parameter werden auf die Werkseinstellungen gesetzt. Warten Sie, bis die STATE-LED sehr schnell weiß blinkt. Anschließend alle DIP-Schalter auf AUS stellen und das Modul neu starten (=0: Für die Kommunikation wird das MODBUS/TCP-Protokoll verwendet =1: Für die Kommunikation wird MODBUS/RTU über Ethernet oder das ASCII-Protokoll verwendet</p> <p>8=CFG CONFIG Dieser DIP-Schalter aktiviert die komplette Grundkonfiguration des Moduls. Wird dieser DIP-Schalter beim Booten in Kombination mit dem DIP-Schalter 7=M gesetzt, führt das Modul einen kompletten System-Reset auf Standard-Werte durch. Der STATIC IP-Modus wird verwendet Die Standard-IP-Einstellungen des Moduls werden aktiviert Der Benutzername und das Passwort für die Webseite sind auf Standardwerte gesetzt Je nach DIP-Schalter 7=M ist MODBUS/TCP oder MODBUS/RTU via Ethernet oder das ASCII-Protokollmodus aktiviert Warten Sie, bis die STATE-LED sehr schnell weiß blinkt. Anschließend alle DIP-Schalter auf AUS stellen und das Modul neu starten (Aus- und wieder einschalten)!</p>	ID3	ID2	ID1	ID0	MODBUS Unit ID oder ASCII-Busnummer	1=ID0				255	2=ID1				1	3=ID2	AUS	AUS	AUS	2	4=ID3	AUS	AUS	EIN	3		AUS	AUS	EIN	4		AUS	EIN	AUS	5		AUS	EIN	EIN	6		AUS	EIN	EIN	7		EIN	AUS	AUS	8		EIN	AUS	AUS	9		EIN	AUS	EIN	10		EIN	AUS	EIN	11		EIN	EIN	AUS	12		EIN	EIN	AUS	13		EIN	EIN	EIN	14
ID3	ID2	ID1	ID0	MODBUS Unit ID oder ASCII-Busnummer																																																																													
1=ID0				255																																																																													
2=ID1				1																																																																													
3=ID2	AUS	AUS	AUS	2																																																																													
4=ID3	AUS	AUS	EIN	3																																																																													
	AUS	AUS	EIN	4																																																																													
	AUS	EIN	AUS	5																																																																													
	AUS	EIN	EIN	6																																																																													
	AUS	EIN	EIN	7																																																																													
	EIN	AUS	AUS	8																																																																													
	EIN	AUS	AUS	9																																																																													
	EIN	AUS	EIN	10																																																																													
	EIN	AUS	EIN	11																																																																													
	EIN	EIN	AUS	12																																																																													
	EIN	EIN	AUS	13																																																																													
	EIN	EIN	EIN	14																																																																													
<p>Technische Information</p> <p>Betriebstemperatur 0..+55°C Lagerungstemperatur -20..+80°C Feuchte 25..90%r.F. nicht kondensierend Spannungsversorgung: 12-48V= Leistungsaufnahme: 7.3W Klemmen Klemmentyp RM5 Kabelquerschnitt: max. 2.5 mm², max. 14AWG Schraube: M3 Anzugsmoment: max. 0.5Nm, max. 4.43 Lb-in</p> <p>Klemmentyp RM3.5 Kabelquerschnitt: max. 1.5 mm², max. 16AWG Schraube: M2 Anzugsmoment: max. 0.2Nm, max. 1.77 Lb-in</p> <p>Abmessungen (LxBxH) 72x110x62mm Gewicht: 210g Gehäuse: 4TE Montage: Schnappbar auf EN50022 DIN Schiene oder Wandmontage Zertifizierung: CE Schutzklasse: IP20 TARIC Nummer: 8538 90 91</p>	<p>STANDARD IP EINSTELLUNGEN:</p> <table border="1"> <tbody> <tr><td>IP ADRESSE:</td><td>192.168.1.64</td></tr> <tr><td>IP MASKE :</td><td>255.255.255.0</td></tr> <tr><td>IP GATEWAY</td><td>192.168.1.1</td></tr> <tr><td>UNIT ID</td><td>abhängig von ID DIP Switch</td></tr> </tbody> </table> <p>BENUTZERNAME: RESI PASSWORD: RESI</p> <p>HINWEIS: Um eine andere IP-Adresse zu konfigurieren, öffnen Sie http://192.168.1.64 in Ihrem Webbrowser und melden Sie sich mit obigem Benutzernamen und Passwort an!</p>	IP ADRESSE:	192.168.1.64	IP MASKE :	255.255.255.0	IP GATEWAY	192.168.1.1	UNIT ID	abhängig von ID DIP Switch																																																																								
IP ADRESSE:	192.168.1.64																																																																																
IP MASKE :	255.255.255.0																																																																																
IP GATEWAY	192.168.1.1																																																																																
UNIT ID	abhängig von ID DIP Switch																																																																																

WICHTIG: Bevor Sie mit der Installation des Produkts beginnen, lesen Sie die beigefügten **WICHTIGEN SICHERHEITSHINWEISE** aufmerksam durch und befolge Sie diese Informationen sorgfältig!

Beschreibung:

Unsere universellen analogen Ein- und Ausgänge sind darauf ausgelegt, die Verwendung analoger E/As zu vereinfachen. Jeder Kanal ist per Software auf einen der folgenden Modi konfigurierbar:

- ANALOG EINGANG: 0-10V oder 2-10V
- ANALOG EINGANG: 0-20mA oder 4-20mA Externe Versorgung
- ANALOG EINGANG: 0-20mA oder 4-20mA Schleifenversorgung
- ANALOG AUSGANG: 0-10V oder 2-10V
- ANALOG AUSGANG: 0-20mA oder 4-20mA
- DIGITAL EINGANG: Logik Eingang: $\leq 40V$, $\leq 1.8mA$, Schwelle 12V = oder Schleifeneingang (4mA)
- OHM MESSUNG: 0-1M Ω
- RTD SENSOR EINGANG: PT100, PT1000, NI1000-DIN43760 2-Leiter

ANALOG EINGANG

0-20mA/4-20mA

Modus: Externe Versorgung

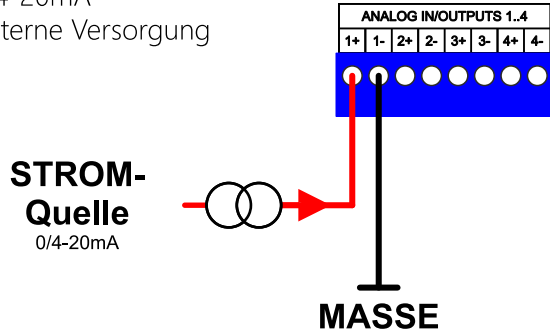

ANALOG EINGANG

0-20mA/4-20mA

Modus: Schleifenversorgung

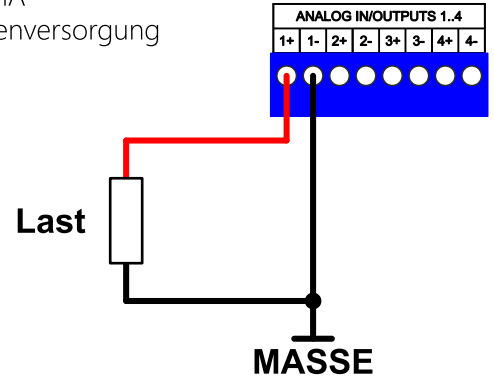

ANALOG EINGANG

0-10V/2-10V

SPANNUNGS-
Quelle
0/2-10V

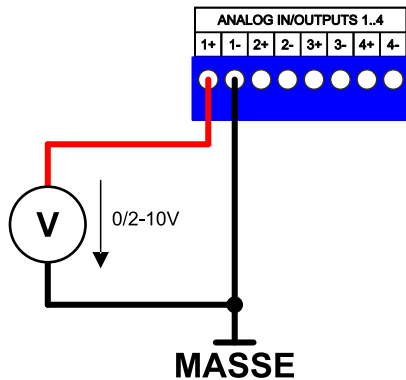

ANALOG MASSE

Alle analogen Masse sind intern miteinander verbunden!

Dies betrifft alle AIOX-Eingänge!
Diese analoge Masse ist jedoch galvanisch vom M- des Moduls getrennt!

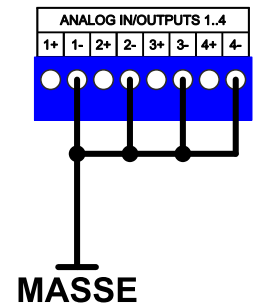

WICHTIG: Bevor Sie mit der Installation des Produkts beginnen, lesen Sie die beigefügten **WICHTIGEN SICHERHEITSHINWEISE** aufmerksam durch und befolgen Sie diese Informationen sorgfältig!

ANALOG AUSGANG

0-20mA/4-20mA

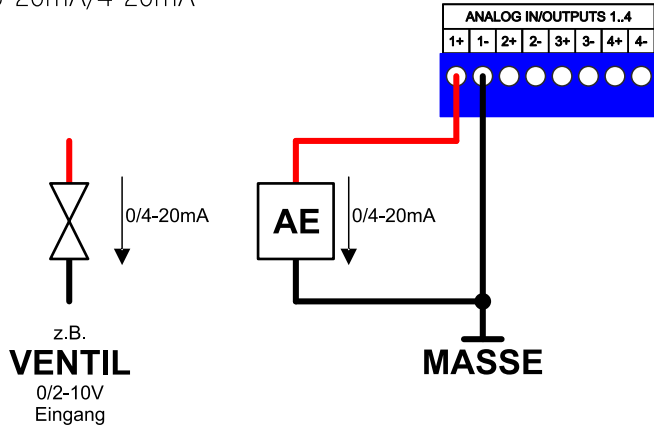

ANALOG AUSGANG

0-10V/2-10V

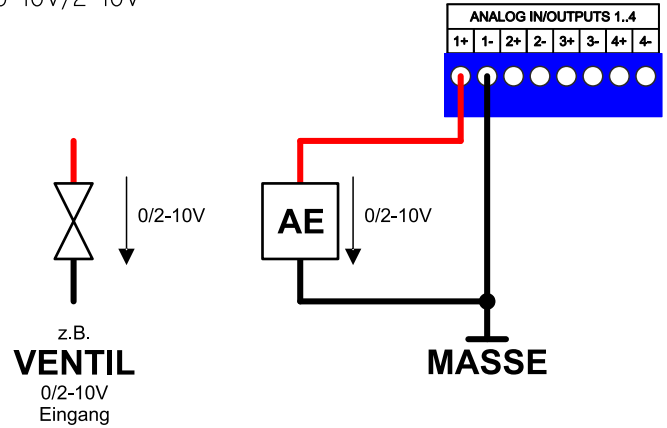

DIGITAL EINGANG

≤40V, 1.8mA
Schwelle 12V=
Logik

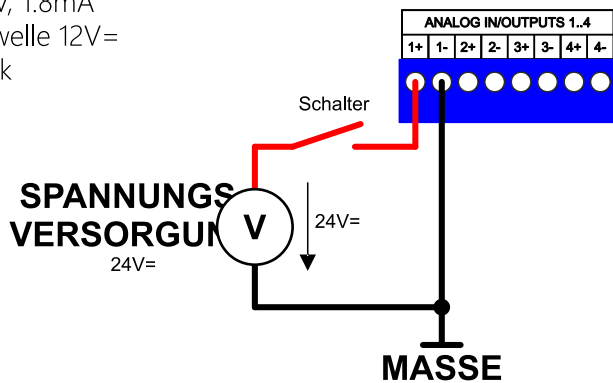

DIGITAL EINGANG

Schleifenversorgung
4mA

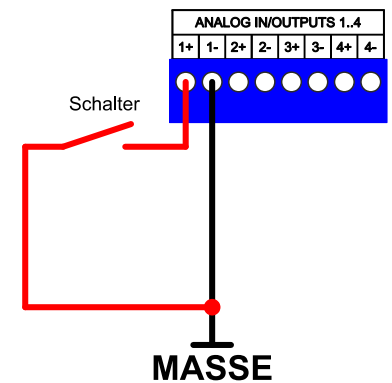

WIDERSTANDS EINGANG

0-1MΩ

Messbereich
0-80Ω
80-200Ω
200-1kΩ
1k-10kΩ
10k-20kΩ
20k-100kΩ
100k-200kΩ
200k-1MΩ

Widerstand

Genauigkeit
±0.5%±0.5Ω
±0.3%
±0.2%
±0.2%
±0.3%
±0.8%
±1.0%
±8%

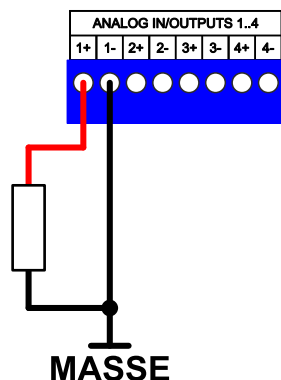

WIDERSTANDS EINGANG

PT100, PT1000, NI1000-DIN43760
interne Linearisierung
Ausgabe: °C, °F oder °K

**RTD
Sensor**
2 wire

Sensor Typ
PT100
PT1000
NI1000-DIN43760

Genauigkeit
±0.3%
±0.2%
±0.2%

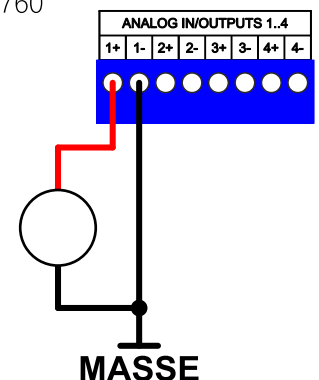

IMPORTANT: Before you start with the installation of the product, read the attached **IMPORTANT SAFETY NOTES** very carefully and follow all the herein given information very accurate!

Description:

IO module with Ethernet and MODBUS/TCP server and ASCII text protocol, 16 universal analog inputs or outputs, 0-10V, 0/4-20mA, RTD sensors 0-1M Ω , PT100, PT1000, NI1000, logic input: $\leq 40V$, $\leq 1.8mA$, individually configurable per channel, Size (LxBxH):72x110x62mm, Weight:210g, Power supply:12-48V=, Power consumption:7.3W, Housing:4MU, Mounting:mountable onto a EN50022 DIN rail or wall mounting, Terminals:Terminal type Pitch 5, Cable cross section: max. 2.5 mm², max. 14AWG, Screw: M3, Tightening torque: max. 0.5Nm, max. 4.43 Lb-in, Terminal type Pitch 3.5, Cable cross section: max. 1.5 mm², max. 16AWG, Screw: M2, Tightening torque: max. 0.2Nm, max. 1.77 Lb-in, Certification:CE, Protection class:IP20, TARIC number:8538 90 91

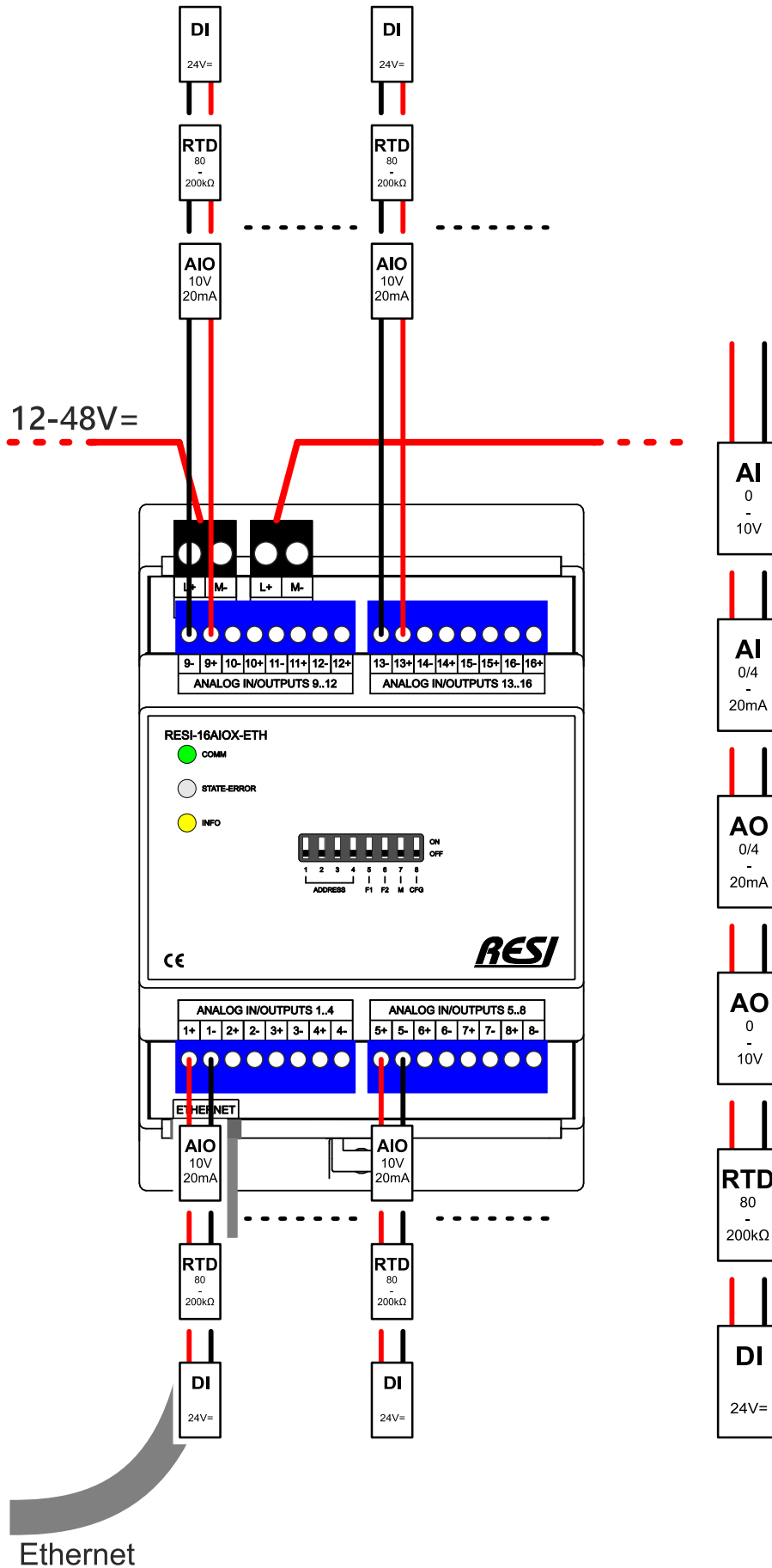

IMPORTANT: Before you start with the installation of the product, read the attached **IMPORTANT SAFETY NOTES** very carefully and follow all the herein given information very accurate!

<p>TERMINALS: L+, M- Two 2-pin plug-in terminals Pitch 5 Power supply for daisy-chain IN and OUT of many IO modules 1 L+ 12-48 V= 2 M- Ground</p> <p>ETH Ethernet interface</p> <p>UNIVERSAL ANALOG IN/OUTPUTS Sixteen 2-pin plug-in terminals Pitch 3.5 Each IO individually configurable: Analog input 0-10V Analog output 0-10V Analog input 0/4-20mA Analog output 0/4-20mA RTD sensor input 0-200kOhm Digital input 24V</p> <p>TERMINAL 1.16 2-pin plug-in terminal 1 AIOX+ Positive signal for AI/AO/RTDI/DI 2 AIOX- Negative signal for AI/AO/RTDI/DI</p> <p>LEDs: COMM Shows whether data is currently being sent or received via the Ethernet interface</p> <p>STATE-ERROR State LED, flashes slowly (approx. 1s) in WHITE if the module is OK. Flashes quickly in RED when the module has an internal error</p> <p>INFO Flashes cyclically as a sign that the analog part is working correctly</p>	<p>DIP SWITCH: ADDRESS This four DIP switches ID3-ID0 create the MODBUS unit number or ASCII bus address. You can use the following settings: Wait for the STATE LED to flash white very quickly. Then set all DIP switches to OFF and restart the module (switch off and on again)!</p> <table border="1"> <thead> <tr> <th>1=ID0</th> <th>ID3</th> <th>ID2</th> <th>ID1</th> <th>ID0</th> <th>MODBUS unit number or ASCII bus number</th> </tr> </thead> <tbody> <tr><td>2=ID1</td><td></td><td></td><td></td><td></td><td>255</td></tr> <tr><td>3=ID2</td><td>OFF</td><td>OFF</td><td>OFF</td><td>OFF</td><td>1</td></tr> <tr><td>4=ID3</td><td>OFF</td><td>OFF</td><td>OFF</td><td>ON</td><td>2</td></tr> <tr><td></td><td>OFF</td><td>OFF</td><td>ON</td><td>OFF</td><td>3</td></tr> <tr><td></td><td>OFF</td><td>OFF</td><td>ON</td><td>ON</td><td>4</td></tr> <tr><td></td><td>OFF</td><td>ON</td><td>OFF</td><td>OFF</td><td>5</td></tr> <tr><td></td><td>OFF</td><td>ON</td><td>OFF</td><td>ON</td><td>6</td></tr> <tr><td></td><td>OFF</td><td>ON</td><td>ON</td><td>ON</td><td>7</td></tr> <tr><td></td><td>ON</td><td>OFF</td><td>OFF</td><td>OFF</td><td>8</td></tr> <tr><td></td><td>ON</td><td>OFF</td><td>OFF</td><td>ON</td><td>9</td></tr> <tr><td></td><td>ON</td><td>OFF</td><td>ON</td><td>OFF</td><td>10</td></tr> <tr><td></td><td>ON</td><td>OFF</td><td>ON</td><td>ON</td><td>11</td></tr> <tr><td></td><td>ON</td><td>ON</td><td>OFF</td><td>OFF</td><td>12</td></tr> <tr><td></td><td>ON</td><td>ON</td><td>OFF</td><td>ON</td><td>13</td></tr> <tr><td></td><td>ON</td><td>ON</td><td>ON</td><td>OFF</td><td>14</td></tr> <tr><td></td><td>ON</td><td>ON</td><td>ON</td><td>ON</td><td>Internal MODBUS unit number is used from the FLASH memory in the range of 0 to 255.</td></tr> </tbody> </table> <p>5=F1 DHCP Enabling this DIP switch at boot changes the internal IP configuration to DHCP settings for the Ethernet. Wait for the STATE LED to flash white very quickly. Then set all DIP switches to OFF and restart the module (switch off and on again)!</p> <p>6=F2 STATIC If this DIP switch is activated at power up, the internal IP configuration is changed to STATIC settings for the Ethernet with the module's default IP address. Wait for the STATE LED to flash white very quickly. Then set all DIP switches to OFF and restart the module (switch off and on again)!</p> <p>7=M MODE This DIP switch is used in conjunction with DIP switch 8=CFG. If this DIP switch is set to 0 (OFF) or 1 (ON) at power up and DIP switch 8=CFG is set to 1 (ON), a full configuration and factory reset of the module occurs: The IP interface is set to STATIC IP address with the module's default IP address, the username and password are changed to default values, and all module-specific parameters are set to factory defaults. Wait for the STATE LED to flash white very quickly. Then set all DIP switches to OFF and restart the module (switch off and on again)!</p> <p>=0: The MODBUS/TCP protocol is used for communication =1: MODBUS/RTU is used for communication via Ethernet or uses the ASCII protocol</p> <p>8=CFG CONFIG This DIP switch activates the complete basic configuration of the module. When booting, this DIP switch is used in combination with the DIP switch 7=M, the module performs a full system reset to default values through. STATIC IP mode is used. The default IP settings of the module are activated. The username and password for the website are set to default values. Depending on the DIP switch 7=M, MODBUS/TCP or MODBUS/RTU via Ethernet or the ASCII protocol mode is activated. Wait for the STATE LED to flash white very quickly. Then set all DIP switches to OFF and restart the module (switch off and on again)!</p>	1=ID0	ID3	ID2	ID1	ID0	MODBUS unit number or ASCII bus number	2=ID1					255	3=ID2	OFF	OFF	OFF	OFF	1	4=ID3	OFF	OFF	OFF	ON	2		OFF	OFF	ON	OFF	3		OFF	OFF	ON	ON	4		OFF	ON	OFF	OFF	5		OFF	ON	OFF	ON	6		OFF	ON	ON	ON	7		ON	OFF	OFF	OFF	8		ON	OFF	OFF	ON	9		ON	OFF	ON	OFF	10		ON	OFF	ON	ON	11		ON	ON	OFF	OFF	12		ON	ON	OFF	ON	13		ON	ON	ON	OFF	14		ON	ON	ON	ON	Internal MODBUS unit number is used from the FLASH memory in the range of 0 to 255.
1=ID0	ID3	ID2	ID1	ID0	MODBUS unit number or ASCII bus number																																																																																																		
2=ID1					255																																																																																																		
3=ID2	OFF	OFF	OFF	OFF	1																																																																																																		
4=ID3	OFF	OFF	OFF	ON	2																																																																																																		
	OFF	OFF	ON	OFF	3																																																																																																		
	OFF	OFF	ON	ON	4																																																																																																		
	OFF	ON	OFF	OFF	5																																																																																																		
	OFF	ON	OFF	ON	6																																																																																																		
	OFF	ON	ON	ON	7																																																																																																		
	ON	OFF	OFF	OFF	8																																																																																																		
	ON	OFF	OFF	ON	9																																																																																																		
	ON	OFF	ON	OFF	10																																																																																																		
	ON	OFF	ON	ON	11																																																																																																		
	ON	ON	OFF	OFF	12																																																																																																		
	ON	ON	OFF	ON	13																																																																																																		
	ON	ON	ON	OFF	14																																																																																																		
	ON	ON	ON	ON	Internal MODBUS unit number is used from the FLASH memory in the range of 0 to 255.																																																																																																		
<p>Technical Information Operating temperature 0..+55°C Storage temperature -20..+80°C Humidity 25..90%r.H. not condensing Power supply: 12-48V= Power consumption: 7.3W Terminals Terminal type Pitch 5 Cable cross section: max. 2.5 mm², max. 14AWG Screw: M3 Tightening torque: max. 0.5Nm, max. 4.43 Lb-in</p> <p>Terminal type Pitch 3.5 Cable cross section: max. 1.5 mm², max. 16AWG Screw: M2 Tightening torque: max. 0.2Nm, max. 1.77 Lb-in</p> <p>Dimensions (LxWxH) 72x110x62mm Weight: 210g Housing: 4MU Mounting: mountable onto a EN50022 DIN rail or wall mounting Certification: CE Protection class: IP20 TARIC number: 8538 90 91</p>	<p>DEFAULT IP SETTINGS:</p> <table border="1"> <tbody> <tr><td>IP ADDRESS:</td><td>192.168.1.64</td></tr> <tr><td>IP MASK :</td><td>255.255.255.0</td></tr> <tr><td>IP GATEWAY</td><td>192.168.1.1</td></tr> <tr><td>UNIT ID</td><td>depending on ID DIP Switch</td></tr> </tbody> </table> <p>USERNAME: RESI PASSWORD: RESI</p> <p>HINT: To configure a different IP address open http://192.168.1.64 in your web browser and login with the above username and password!</p>	IP ADDRESS:	192.168.1.64	IP MASK :	255.255.255.0	IP GATEWAY	192.168.1.1	UNIT ID	depending on ID DIP Switch																																																																																														
IP ADDRESS:	192.168.1.64																																																																																																						
IP MASK :	255.255.255.0																																																																																																						
IP GATEWAY	192.168.1.1																																																																																																						
UNIT ID	depending on ID DIP Switch																																																																																																						

IMPORTANT: Before you start with the installation of the product, read the attached **IMPORTANT SAFETY NOTES** very carefully and follow all the herein given information very accurate!

Description:

Our universal analog inputs and outputs are designed to ease the use of analog IOs. Every channel is configurable via software to one of the following modes:

- ANALOG INPUT: 0-10V or 2-10V
- ANALOG INPUT: 0-20mA or 4-20mA external powered mode
- ANALOG INPUT: 0-20mA or 4-20mA loop power mode
- ANALOG OUTPUT: 0-10V or 2-10V
- ANALOG OUTPUT: 0-20mA or 4-20mA
- DIGITAL INPUT: logic input: $\leq 40V$, $\leq 1.8mA$, threshold 12V = or loop powered digital input (4mA)
- OHM MEASUREMENT: 0-1M Ω
- RTD SENSOR INPUT: PT100, PT1000, NI1000-DIN43760 2 wire

ANALOG INPUT

0-20mA/4-20mA

External powered mode

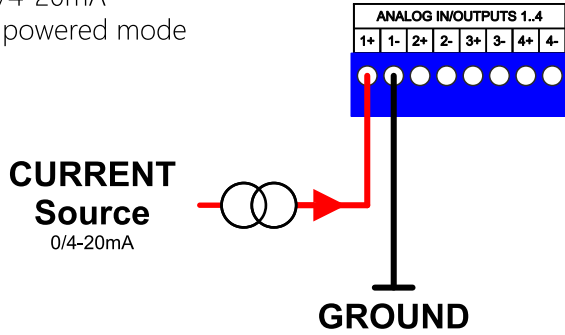

ANALOG INPUT

0-20mA/4-20mA

Loop powered mode

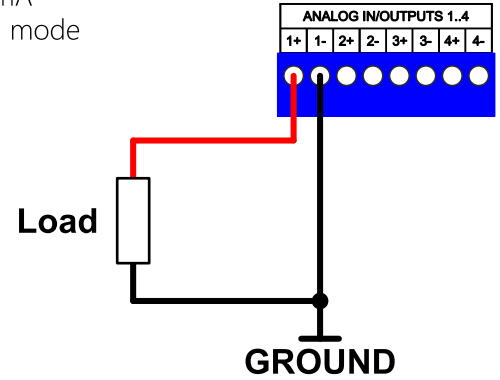

ANALOG INPUT

0-10V/2-10V

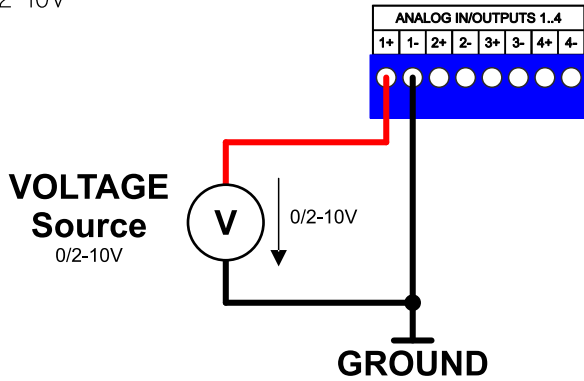

ANALOG GROUND

All analog grounds are internally tied together!

This affects to all AIOX inputs!
But this analog ground is galvanically isolated from the M- of the module!

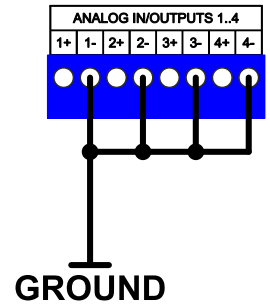

IMPORTANT: Before you start with the installation of the product, read the attached **IMPORTANT SAFETY NOTES** very carefully and follow all the herein given information very accurate!

ANALOG OUTPUT

0-20mA/4-20mA

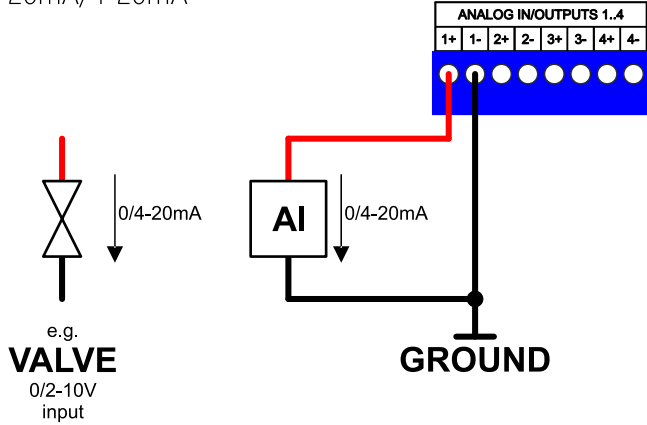

ANALOG OUTPUT

0-10V/2-10V

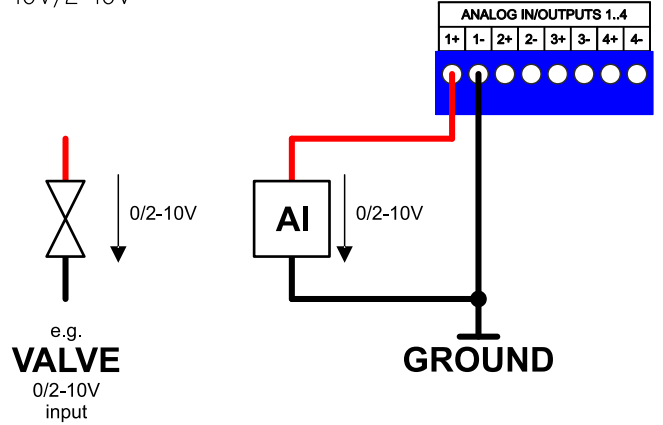

DIGITAL INPUT

≤40V, 1.8mA
Threshold 12V=
Logic

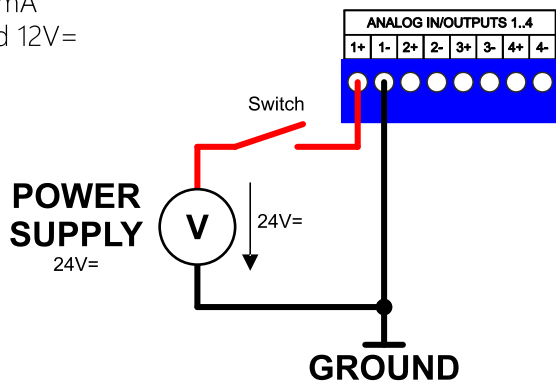

DIGITAL INPUT

Loop powered
4mA

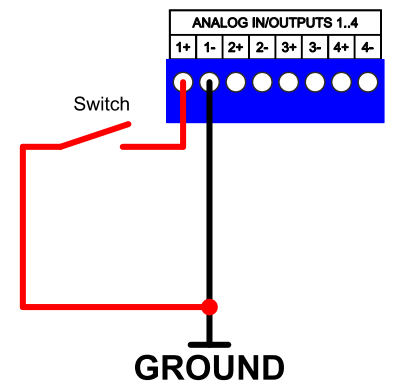

RESISTOR INPUT

0-1MΩ

Measurement Range	Accuracy
0-80Ω	±0.5%±0.5Ω
80-200Ω	±0.3%
200-1kΩ	±0.2%
1k-10kΩ	±0.2%
10k-20kΩ	±0.3%
20k-100kΩ	±0.8%
100k-200kΩ	±1.0%
200k-1MΩ	±8%

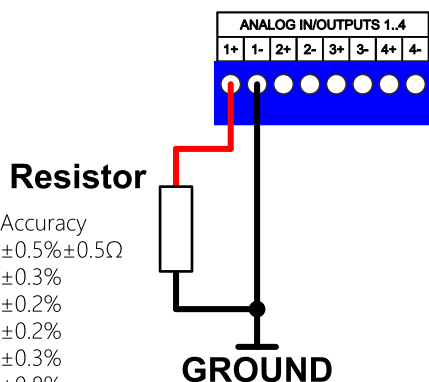

RESISTOR INPUT

PT100, PT1000, NI1000-DIN43760
internal linearisation
Output: °C, °F or °K

Sensor type	Accuracy
PT100	±0.3%
PT1000	±0.2%
NI1000-DIN43760	±0.2%

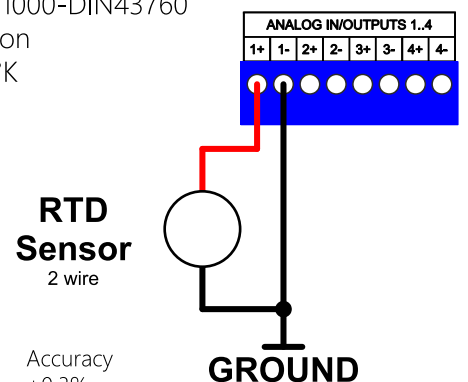

Wichtige Hinweise:

- **Vor der Installation und Inbetriebnahme ist dieser Sicherheitshinweis, die beigelegte Installationsanleitung und das dazugehörige Handbuch zu lesen und alle darin gemachten Hinweise sind zu beachten!**
- Die Installation der Geräte darf nur durch Fachpersonal durchgeführt werden!
- Der Anschluss der Geräte darf nur im spannungslosen Zustand erfolgen!
- Führen Sie bei eingeschaltetem Gerät keine elektrischen Arbeiten am Gerät aus!
- Sichern Sie das Gerät gegen Wiedereinschalten!
- Das Gerät darf nur mit der vorgeschriebenen Spannung versorgt werden!
- Schwankungen und Abweichungen der Netzspannung vom Nennwert dürfen die in den technischen Daten angegebenen Toleranzgrenzen und Vorgaben nicht überschreiten. Bei Nichteinhaltung kann es zu Funktionsbeeinträchtigungen und Funktionsstörungen kommen!
- Es sind die aktuellen EMV Richtlinien in der Verkabelung zu beachten!
- Alle Signal- und Anschlussleitungen sind so zu verlegen, daß induktive und kapazitive Störungen sowie Einstreuungen die Funktionen des Geräts nicht beeinflussen. Falsche Verkabelung kann zu erheblichen Fehlfunktionen des Geräts führen!
- Für Signalleitungen und Sensorleitungen sind geschirmte Kabel zu verwenden, um Schäden durch Spannungsinduktion zu verhindern!
- Es sind die aktuellen Sicherheitsvorschriften der ÖVE, VDE, der Länder, ihrer Überwachungsorgane, des TÜV und des örtlichen EVUs zu beachten!
- Beachten Sie die länderspezifischen Vorschriften und Normen!
- Das Gerät ist nur für den angegebenen Verwendungszweck zu benutzen!
- Für Mängel und Schäden, die durch unsachgemäße Verwendung der Geräte entstehen, werden keinerlei Gewährleistungen und Haftungen übernommen!
- Folgeschäden, welche durch Fehler an diesem Gerät entstehen, sind von der Gewährleistung und Haftung ausgenommen!
- Es gelten ausschließlich die technischen Daten, Anschlussbedingungen und Bedienungsanleitungen, welche den Geräten bei der Lieferung beigelegt sind!
- Alle auf unserer Homepage, oder in unserem Datenblatt, in unseren Handbüchern, in unseren Katalogen oder bei unseren Partnern publizierten technischen Daten müssen im Sinne des technischen Fortschritts nicht immer aktuell sein!
- Bei Veränderungen unserer Geräte durch den Anwender entfallen alle Gewährleistungsansprüche!
- Die beim Gerät spezifizierten technischen Rahmenbedingungen (zB Temperaturen, Spannungsversorgung, etc.) sind unbedingt einzuhalten!
- Der Betrieb von Geräten in der Nähe zu unseren Geräten, welche nicht den EMV-Richtlinien entsprechen, kann zur Beeinflussung der Funktionsweise unseres Gerätes bis zum Ausfall unseres Gerätes führen!
- Unsere Geräte dürfen nicht für Überwachungszwecke, welche ausschließlich dem Schutz von Personen gegen Gefährdung oder Verletzung dienen und nicht als Not-Aus-Schalter in Anlagen und Maschinen oder vergleichbare sicherheitsrelevante Aufgaben verwendet werden!
- Die Gehäuse- und Gehäusezubehörmäße können geringe Toleranzen zu den Angaben in der Installationsanleitung bzw. zu den Angaben im Handbuch aufweisen!
- Veränderungen dieser Unterlagen sind nicht gestattet!
- Reklamationen werden nur in unserer vollständigen Originalverpackung angenommen!

IMPORTANT SAFETY NOTESConfiguration software and manual available at www.resi.cc**Important hint:**

- **Before you start with the installation and the initial setup of the device, you have to read this document and the attached installation guide and the actual manual for the device very carefully. You have to follow all the herein given information very accurate!**
- Only authorized and qualified personnel are allowed to install and setup the device!
- The connection of the device must be done in de-energized state!
- Do not perform any electrical work while the device is connected to power!
- Disable and secure the system against any automatic restart or power on procedure!
- The device must be operated with the defined voltage level!
- Supply voltage jitters must not exceed the technical specifications and tolerances given in the technical manuals for the product. If you do not obey this issue, the proper performance of the device cannot be guaranteed. This can lead to fail functions of the device and in worst case to a complete breakdown of the device!
- You have to obey the current EMC regulations for wiring!
- All signal, control and supply voltage cables must be wired in a way, that no inductive or capacitive interference or any other severe electrical noise disturbance may interfere with the device. Wrong wiring can lead to a malfunction of the device!
- For signal or sensor cables you have to use shielded cables, to avoid damages through induction!
- You have to obey and to apply the current safety regulations given by the ÖVE, VDE, the countries, their control authorities, the TÜV or the local energy supply company!
- Obey country-specific laws and standards!
- The device must be used for the intended purpose of the manufacturer!
- No warranties or liabilities will be accepted for defects and damages resulting from improper or incorrect usage of the device!
- Subsequent damages, which results from faults of this device, are excluded from warranty and liability!
- Only the technical data, wiring diagrams and operation instructions, which are part to the product shipment are valid!
- The information on our homepage, in our datasheets, in our manuals, in our catalogues or published by our partners can deviate from the product documentation and is not necessarily always actual, due to constant improvement of our products for technical progress!
- In case of modification of our devices made by the user, all warranty and liability claims are lost!
- The installation has to fulfill the technical conditions and specifications (e.g. operating temperatures, power supply, ...) given in the devices documentation!
- Operating our device close to equipment, which do not comply with EMC directives, can influence the functionality of our device, leading to malfunction or in worst case to a breakdown of our device!
- Our devices must not be used for monitoring applications, which solely serve the purpose of protecting persons against hazards or injury, or as an emergency stop switch for systems or machinery, or for any other similar safety-relevant purposes!
- Dimensions of the enclosures or enclosures accessories may show slight tolerances on the specifications provided in these instructions!
- Modifications of this documentation is not allowed!
- In case of a complaint, only complete devices returned in original packing will be accepted!