

WICHTIG: Bevor Sie mit der Installation des Produkts beginnen, lesen Sie die beigefügten **WICHTIGEN SICHERHEITSHINWEISE** aufmerksam durch und befolge Sie diese Informationen sorgfältig!

Beschreibung:
Dieser Controller besteht aus: Raspberry PI 4B® Board, RAM: 2/4/8GB, 32 GB Micro SD Karte mit vorinstalliertem Raspian® LINUX, Gehäuse für DIN Schienen und Wandmontage, 1xCAN 2.0 Schnittstelle mit abziehbarer 3pol Klemme, 3 integrierte native serielle Schnittstellen: 2xRS232 und 1xRS485, Hardwareumschaltung der RS485 Richtung, Jede serielle Schnittstelle besitzt abziehbare 3pol Klemme, 8-pol DIP Switch und 4 LEDs für Status und Fehleranzeige, Integrierte Uhr mit Backup-Kapazität, Ethernet Schnittstelle 10/100/1000Mbit/s, 2xUSB 3.0, 1xUSB 2.0, 2xMiniHDMI 4k, 1xAudio, WLAN b/g/n/ac, Bluetooth® 5.0, Integrierter ARM Co-Prozessor, Integrierte Spannungsversorgung 12-48V= mit zwei abziehbaren 2pol Klemmen, Größe (LxBxH):72x90x62mm, Gewicht:210g, Spannungsversorgung:12-48V=, Leistungsaufnahme:25.0W, Gehäuse:4TE, Montage:DIN EN50022 Schiene oder Wandmontage, Klemmen:Klemmentyp RM5 , Kabelquerschnitt: max. 2.5 mm², max. 14AWG, Schraube: M3, Anzugsmoment: max. 0.5Nm, max. 4.43 Lb-in, Klemmentyp RM3.5, Kabelquerschnitt: max. 1.5 mm², max. 16AWG, Schraube: M2, Anzugsmoment: max. 0.2Nm, max. 1.77 Lb-in, Zertifizierung:CE, TARIC Nummer:8538 90 91

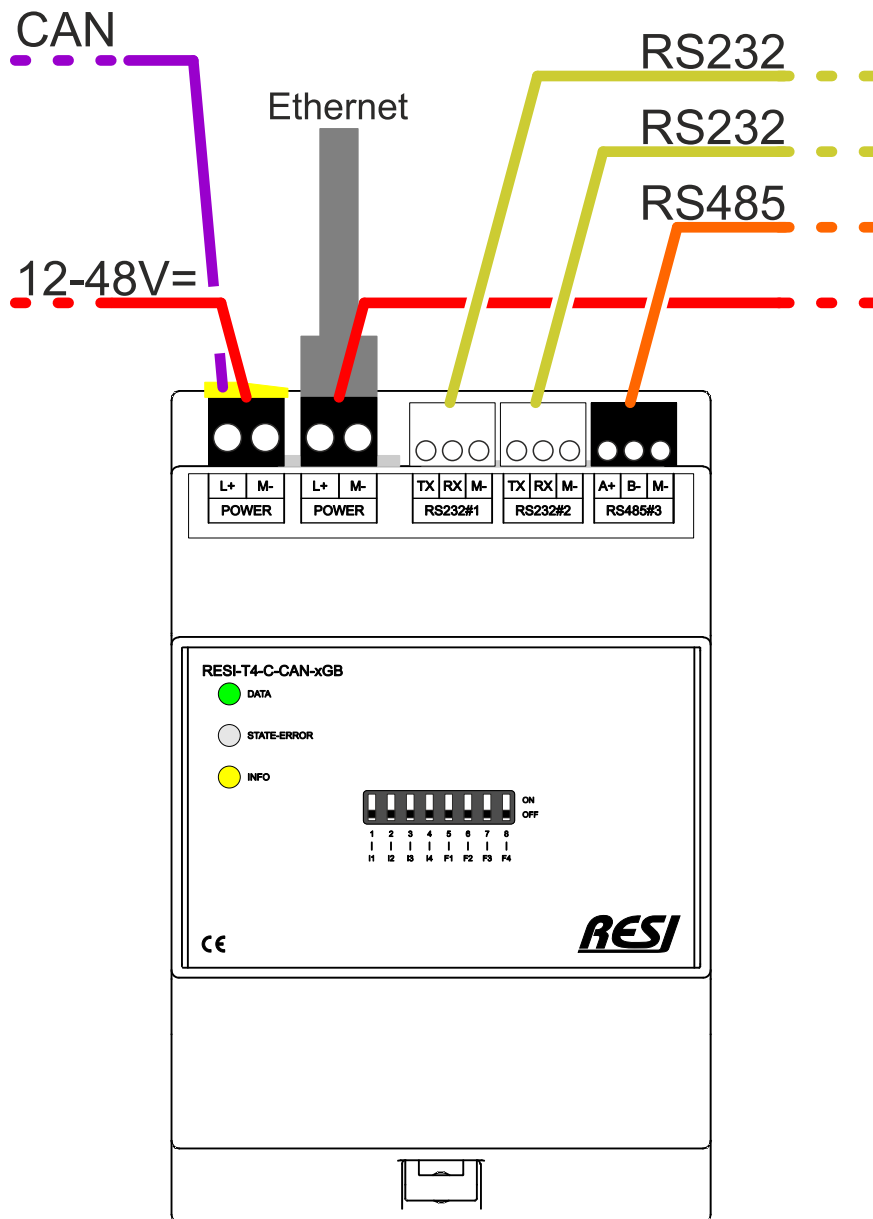

WICHTIG: Bevor Sie mit der Installation des Produkts beginnen, lesen Sie die beigefügten **WICHTIGEN SICHERHEITSHINWEISE** aufmerksam durch und befolge Sie diese Informationen sorgfältig!

<p>KLEMMEN: L+, M- Spannungsversorgung mit zwei getrennten 2 pol Steckklemmen Für Daisy-chain IN und OUT Spannungsversorgung von vielen IO Modulen Pin 1: L+ 12-48 V= Pin 2: M- Masse Klemmentyp: RM5</p> <p>CAN H,L,G SPI von Raspberry Pi CAN/CAN 2.0 Schnittstelle: Pin 1: H CAN DATA+ Signal (High) Pin 2: L CAN DATA- Signal (Low) Pin 3: G CAN Masse Signal Klemmentyp: RM3.5</p> <p>INTERNE SIO LINUX port PDEV0 – ttyACM0 ASCII Kommunikation mit ARM Co-Prozessor</p> <p>RS232#1 TX,RX,M- LINUX port PDEV1 - ttyACM1 RS232 ASCII oder MODBUS/RTU Schnittstelle: Pin 1: TX RS232 Transmit Signal Pin 2: RX RS232 Receive Signal Pin 3: M- RS232 Masse Signal Klemmentyp: RM3.5</p> <p>RS232#2 TX,RX,M- LINUX port PDEV2 - ttyACM2 RS232 ASCII oder MODBUS/RTU Schnittstelle: Pin 1: TX RS232 Transmit Signal Pin 2: RX RS232 Receive Signal Pin 3: M- RS232 Masse Signal Klemmentyp: RM3.5</p> <p>RS485#3 A+,B-,M- LINUX port PDEV3 - ttyACM3 RS485 ASCII oder MODBUS/RTU Schnittstelle: Pin 1: A+ RS485 DATA+ Signal Pin 2: B- RS485 DATA- Signal Pin 3: M- RS485 Masse Signal Klemmentyp: RM3.5 Jumper für 120Ω Abschluss-Widerstand</p> <p>ETHERNET RJ45 ETHERNET Verbindung für Netzwerk oder Internet Zugriff 10M/100M/1000Mbit</p> <p>USB USB Ports des Raspberry PI 2xUSB 3.0 1xUSB 2.0</p> <p>ACHTUNG Ein USB 2.0 Port wird intern verwendet! Dieses ist durch eine Abdeckung geschützt, sodass man keine USB Geräte hier anstecken kann! HIER KEINE USB GERÄTE ANSTECKEN! DAS KANN DAS GERÄT ZERSTÖREN!!</p> <p>MICRO-HDMI1+2 Anschluss für zwei HDMI Monitore Auflösung maximal 2x4k</p> <p>AUDIO OUT Anschluss für eine Audio-Box</p> <p>LEDs: DATA STATE-ERROR INFO Diese LEDs werden über interne ASCII Kommandos von dem Benutzerprogramm gesteuert. Nach einem Neustart des Controllers blinkt die STATE-ERROR LED rot.</p> <p>DIP SWITCH Der aktuelle Zustand dieses 8fach DIP Switches kann vom Benutzerprogramm über den internen Co-Prozessor gelesen werden.</p>	<p>LINUX</p> <p>Benutzer root Passwort r4T4!#</p> <p>Benutzer resi Passwort r4T4!#</p> <p>IP Adresse 192.168.0.11 Maske 255.255.255.0 Gateway 192.168.0.1</p> <p>Benutzen sie ssh oder VNCViewer, um eine Verbindung zum LINUX Controller aufzubauen.</p> <p>Die CAN Schnittstelle ist intern mit dem SPI Bus des Raspberry Pis verbunden. Die CAN Schnittstelle kann über die Standard Open Source CAN Software für den Raspberry Pi angebunden werden. Als CAN Chip wird der Chip MCP2515 verwendet.</p> <p>Der ARM Co-Prozessor ist via USB an das LINUX angebunden und installiert zusätzliche serielle Schnittstellen: dev/ttyACM0 bis dev/ttyACM3. Die Schnittstelle dev/ttyACM0 dient zur internen Kommunikation mit dem ARM Co-Prozessor und die Schnittstellen dev/ttyACM1 bis dev/ttyACM3 dienen zur Kommunikation mit den zusätzlichen RS232/RS485 Schnittstellen. Die Richtungsumschaltung bei den RS485 Schnittstellen erfolgt automatisch durch den ARM Co-Prozessor.</p>
---	---

Technische Information

Betriebstemperatur	0..+50°C
Lagerungstemperatur	-20..+80°C
Feuchte	25..90%r.F. nicht kondensierend
Spannungsversorgung:	12-48V=
Leistungsaufnahme:	25W
Klemmen	Klemmentyp RM5 Kabelquerschnitt: max. 2.5 mm², max. 14AWG Schraube: M3 Anzugsmoment: max. 0.5Nm, max. 4.43 Lb-in
	Klemmentyp RM3.5 Kabelquerschnitt: max. 1.5 mm², max. 16AWG Schraube: M2 Anzugsmoment: max. 0.2Nm, max. 1.77 Lb-in
Abmessungen (LxBxH)	72x110x62mm
Gewicht:	210g
Gehäuse:	4TE
Montage:	Schnappbar auf EN50022 DIN Schiene oder Wandmontage
Zertifizierung:	CE
Schutzklasse:	IP20
TARIC Nummer:	8538 90 91

IMPORTANT: Before you start with the installation of the product, read the attached **IMPORTANT SAFETY NOTES** very carefully and follow all the herein given information very accurate!

Description:

This controller consists of: Raspberry PI 4B® board, RAM: 2/4/8GB, 32 GB Micro SD card with pre-installed Raspian® LINUX, Housing for DIN rail and wall mounting, 1xCAN 2.0 interface with removable 3pin terminal, 3 integrated native serial interfaces: 2xRS232 and 1xRS485, Hardware switching of RS485 direction, Each serial interface has a removable 3-pin terminal, 8-pin DIP switch and 4 LEDs for status and error display, Integrated clock with backup capacity, Ethernet interface 10/100/1000Mbit/s, 2xUSB 3.0, 1xUSB 2.0, 2xMiniHDMI 4k, 1xAudio, WLAN b/g/n/ac, Bluetooth® 5.0, Integrated ARM® co-processor, Integrated power supply 12-48V= with two removable 2-pin terminals, Size (LxBxH):72x90x62mm, Weight:210g, Power supply:12-48V=, Power consumption:25.0W, Housing:4MU, Mounting:DIN EN50022 rail or wall mounting, Terminals:Terminal type RM5 , Cable cross section: max. 2.5 mm², max. 14AWG, Screw: M3, Tightening torque: max. 0.5Nm, max. 4.43 Lb-in, Terminal type RM3.5, Cable cross section: max. 1.5 mm², max. 16AWG, Screw: M2, Tightening torque: max. 0.2Nm, max. 1.77 Lb-in, Certification:CE, TARIC number:8538 90 91

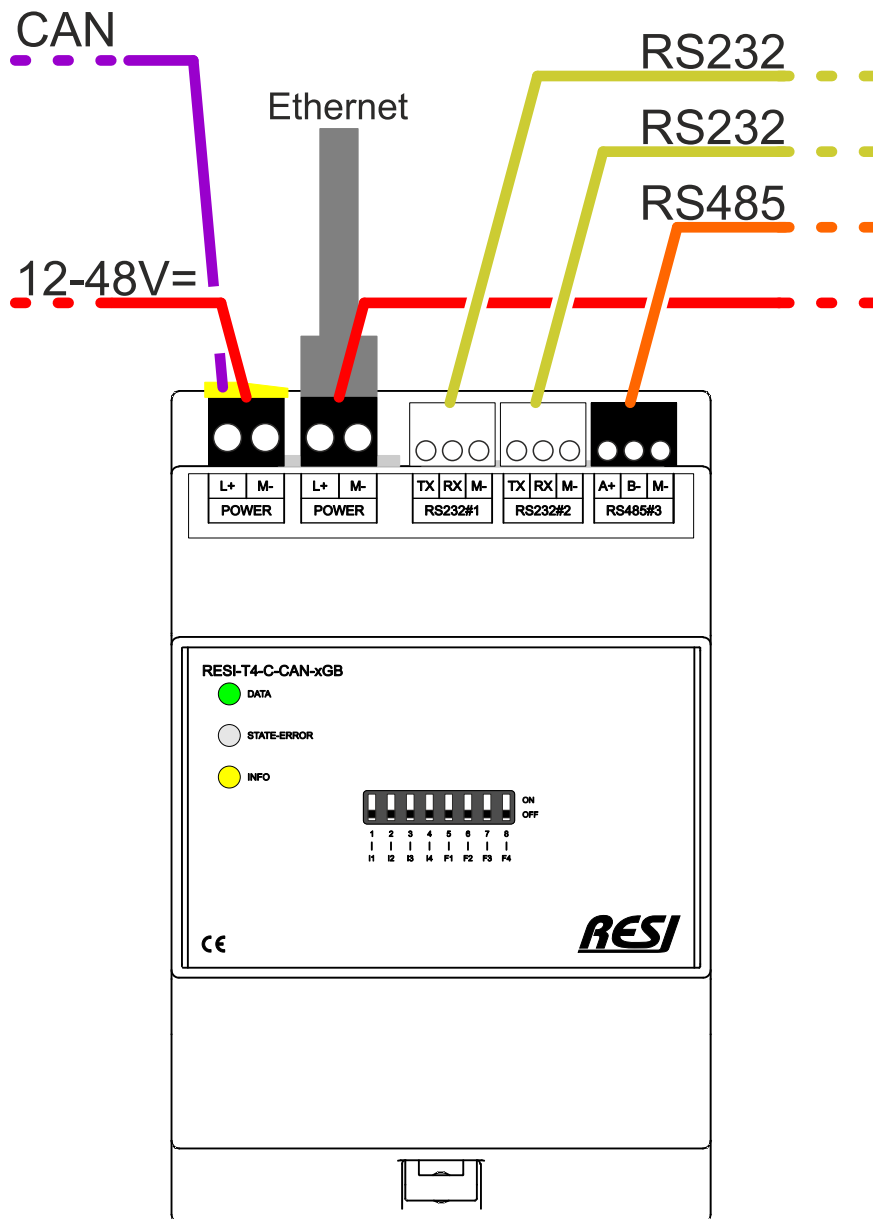

IMPORTANT: Before you start with the installation of the product, read the attached **IMPORTANT SAFETY NOTES** very carefully and follow all the herein given information very accurate!

<p>TERMINALS: L+, M- Power supply via two separated plug-in 2-pin terminal blocks. For daisy chain IN and OUT power supply of many modules Pin 1: L+ 12-48 V= Pin 2: M- Ground Terminal type: RM5</p> <p>CAN H,L,G SPI of Raspberry Pi CAN/CAN 2.0 interface Pin 1: H CAN DATA+ signal (High) Pin 2: L CAN DATA- signal (Low) Pin 3: G CAN ground signal Terminal type: RM3.5</p> <p>INTERNAL SIO LINUX port PDEV0 – ttyACM0 ASCII communication with ARM co-processor</p> <p>RS232#1 TX,RX,M- LINUX port PDEV1 – ttyACM1 RS232 ASCII or MODBUS/RTU interface: Pin 1: TX RS232 transmit signal Pin 2: RX RS232 receive signal Pin 3: M- RS232 ground signal Terminal type: RM3.5</p> <p>RS232#2 TX,RX,M- LINUX port PDEV2 – ttyACM2 RS232 ASCII or MODBUS/RTU interface: Pin 1: TX RS232 transmit signal Pin 2: RX RS232 receive signal Pin 3: M- RS232 ground signal Terminal type: RM3.5</p> <p>RS485#3 A+,B-,M- LINUX port PDEV3 – ttyACM3 RS485 ASCII or MODBUS/RTU interface: Pin 1: A+ RS485 DATA+ signal Pin 2: B- RS485 DATA signal Pin 3: M- RS485 ground signal Terminal type: RM3.5 Jumper for 120Ω terminating resistor</p> <p>ETHERNET RJ45 ETHERNET connection for network or Internet access 10M/100M/1000Mbit</p> <p>USB USB ports of the Raspberry PI 2xUSB 3.0 1xUSB 2.0</p> <p>ATTENTION A USB 2.0 port is used internally! This is protected by a cover so that you cannot plug in any USB devices here! DO NOT PLUG IN USB DEVICES HERE! THIS CAN DESTROY THE DEVICE!!</p> <p>MICRO-HDMI1+2 connection for two HDMI monitors Resolution maximum 2x4k</p> <p>AUDIO OUT Connection for an audio box</p> <p>LEDs: DATA STATE ERROR INFO These LEDs are activated via internal ASCII commands from the user program controlled. After restarting the controller, the STATE-ERROR LED flashes red.</p> <p>DIP SWITCH The current state of this 8-fold DIP switch can be read by the user program via the internal co-processor.</p>	<p>LINUX</p> <p>User root Password r4T4!#</p> <p>User resi Password r4T4!#</p> <p>IP address 192.168.0.11 Mask 255.255.255.0 Gateway 192.168.0.1</p> <p>Use ssh or VNCViewer to establish a connection to the LINUX controller.</p> <p>The CAN interface is internally connected to the SPI bus of the Raspberry Pi. The CAN interface can be connected via the standard open source CAN software for the Raspberry Pi. The MCP2515 chip is used as the CAN chip.</p> <p>The ARM co-processor is connected to the LINUX via USB and installs additional serial interfaces: dev/ttyACM0 to dev/ttyACM3. The interface dev/ttyACM0 is used for internal communication with the ARM co-processor and the interfaces dev/ttyACM1 to dev/ttyACM3 are used for communication with the additional RS232/RS485 interfaces. The direction switching on the RS485 interfaces is carried out automatically by the ARM co-processor.</p>
---	--

Technical Information

Operating temperature	0..+50°C
Storage temperature	-20..+80°C
Humidity	25..90%r.H. not condensing
Power supply:	12-48V=
Power consumption:	25W
Terminals	Terminal type RM5 Cable cross section: max. 2.5 mm ² , max. 14AWG Screw: M3 Tightening torque: max. 0.5Nm, max. 4.43 Lb-in
	Terminal type RM3.5 Cable cross section: max. 1.5 mm ² , max. 16AWG Screw: M2 Tightening torque: max. 0.2Nm, max. 1.77 Lb-in
Dimensions (LxWxH)	72x110x62mm
Weight:	210g
Housing:	4MU
Mounting:	mountable onto a EN50022 DIN rail or wall mounting
Certification:	CE
Protection class:	IP20
TARIC number:	8538 90 91

Wichtige Hinweise:

- **Vor der Installation und Inbetriebnahme ist dieser Sicherheitshinweis, die beigelegte Installationsanleitung und das dazugehörige Handbuch zu lesen und alle darin gemachten Hinweise sind zu beachten!**
- Die Installation der Geräte darf nur durch Fachpersonal durchgeführt werden!
- Der Anschluss der Geräte darf nur im spannungslosen Zustand erfolgen!
- Führen Sie bei eingeschaltetem Gerät keine elektrischen Arbeiten am Gerät aus!
- Sichern Sie das Gerät gegen Wiedereinschalten!
- Das Gerät darf nur mit der vorgeschriebenen Spannung versorgt werden!
- Schwankungen und Abweichungen der Netzspannung vom Nennwert dürfen die in den technischen Daten angegebenen Toleranzgrenzen und Vorgaben nicht überschreiten. Bei Nichteinhaltung kann es zu Funktionsbeeinträchtigungen und Funktionsstörungen kommen!
- Es sind die aktuellen EMV Richtlinien in der Verkabelung zu beachten!
- Alle Signal- und Anschlussleitungen sind so zu verlegen, daß induktive und kapazitive Störungen sowie Einstreuungen die Funktionen des Geräts nicht beeinflussen. Falsche Verkabelung kann zu erheblichen Fehlfunktionen des Geräts führen!
- Für Signalleitungen und Sensorleitungen sind geschirmte Kabel zu verwenden, um Schäden durch Spannungsinduktion zu verhindern!
- Es sind die aktuellen Sicherheitsvorschriften der ÖVE, VDE, der Länder, ihrer Überwachungsorgane, des TÜV und des örtlichen EVUs zu beachten!
- Beachten Sie die länderspezifischen Vorschriften und Normen!
- Das Gerät ist nur für den angegebenen Verwendungszweck zu benutzen!
- Für Mängel und Schäden, die durch unsachgemäße Verwendung der Geräte entstehen, werden keinerlei Gewährleistungen und Haftungen übernommen!
- Folgeschäden, welche durch Fehler an diesem Gerät entstehen, sind von der Gewährleistung und Haftung ausgenommen!
- Es gelten ausschließlich die technischen Daten, Anschlussbedingungen und Bedienungsanleitungen, welche den Geräten bei der Lieferung beigelegt sind!
- Alle auf unserer Homepage, oder in unserem Datenblatt, in unseren Handbüchern, in unseren Katalogen oder bei unseren Partnern publizierten technischen Daten müssen im Sinne des technischen Fortschritts nicht immer aktuell sein!
- Bei Veränderungen unserer Geräte durch den Anwender entfallen alle Gewährleistungsansprüche!
- Die beim Gerät spezifizierten technischen Rahmenbedingungen (zB Temperaturen, Spannungsversorgung, etc.) sind unbedingt einzuhalten!
- Der Betrieb von Geräten in der Nähe zu unseren Geräten, welche nicht den EMV-Richtlinien entsprechen, kann zur Beeinflussung der Funktionsweise unseres Gerätes bis zum Ausfall unseres Gerätes führen!
- Unsere Geräte dürfen nicht für Überwachungszwecke, welche ausschließlich dem Schutz von Personen gegen Gefährdung oder Verletzung dienen und nicht als Not-Aus-Schalter in Anlagen und Maschinen oder vergleichbare sicherheitsrelevante Aufgaben verwendet werden!
- Die Gehäuse- und Gehäusezubehörmäße können geringe Toleranzen zu den Angaben in der Installationsanleitung bzw. zu den Angaben im Handbuch aufweisen!
- Veränderungen dieser Unterlagen sind nicht gestattet!
- Reklamationen werden nur in unserer vollständigen Originalverpackung angenommen!

IMPORTANT SAFETY NOTES

Configuration software and manual available at www.resi.cc

Important hint:

- **Before you start with the installation and the initial setup of the device, you have to read this document and the attached installation guide and the actual manual for the device very carefully. You have to follow all the herein given information very accurate!**
- Only authorized and qualified personnel are allowed to install and setup the device!
- The connection of the device must be done in de-energized state!
- Do not perform any electrical work while the device is connected to power!
- Disable and secure the system against any automatic restart or power on procedure!
- The device must be operated with the defined voltage level!
- Supply voltage jitters must not exceed the technical specifications and tolerances given in the technical manuals for the product. If you do not obey this issue, the proper performance of the device cannot be guaranteed. This can lead to fail functions of the device and in worst case to a complete breakdown of the device!
- You have to obey the current EMC regulations for wiring!
- All signal, control and supply voltage cables must be wired in a way, that no inductive or capacitive interference or any other severe electrical noise disturbance may interfere with the device. Wrong wiring can lead to a malfunction of the device!
- For signal or sensor cables you have to use shielded cables, to avoid damages through induction!
- You have to obey and to apply the current safety regulations given by the ÖVE, VDE, the countries, their control authorities, the TÜV or the local energy supply company!
- Obey country-specific laws and standards!
- The device must be used for the intended purpose of the manufacturer!
- No warranties or liabilities will be accepted for defects and damages resulting from improper or incorrect usage of the device!
- Subsequent damages, which results from faults of this device, are excluded from warranty and liability!
- Only the technical data, wiring diagrams and operation instructions, which are part to the product shipment are valid!
- The information on our homepage, in our datasheets, in our manuals, in our catalogues or published by our partners can deviate from the product documentation and is not necessarily always actual, due to constant improvement of our products for technical progress!
- In case of modification of our devices made by the user, all warranty and liability claims are lost!
- The installation has to fulfill the technical conditions and specifications (e.g. operating temperatures, power supply, ...) given in the devices documentation!
- Operating our device close to equipment, which do not comply with EMC directives, can influence the functionality of our device, leading to malfunction or in worst case to a breakdown of our device!
- Our devices must not be used for monitoring applications, which solely serve the purpose of protecting persons against hazards or injury, or as an emergency stop switch for systems or machinery, or for any other similar safety-relevant purposes!
- Dimensions of the enclosures or enclosures accessories may show slight tolerances on the specifications provided in these instructions!
- Modifications of this documentation is not allowed!
- In case of a complaint, only complete devices returned in original packing will be accepted!